

Why Zagreb Radial Riveting ?

Because the improved, revolutionary technique with cycloidal movement of the peen replaces the current hammering, rolling and wobbling (orbital – spin) techniques or riveting and our radial riveting system produces a better rivet fusion

The unique cycloidal movement permits working with low pressure which guards riveted parts against damage.

Fast riveting cycles save time / higher production & efficiency.

A wide variety of riveting programs possible.

Uniform, smooth flow of rivet material prevents molecular destruction within the material. No damages to galvanic, plating, copper, or relevant surface coatings.

Also case-hardened and through –hardened rivets can normally be riveted. Practically no lateral forces, makes free riveting possible.

Simple, low cost peens can easily be made in any work-shop.

Little Space Required.

All this without noise.

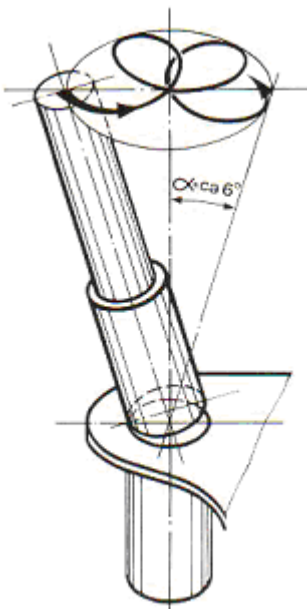

ZAGREB

Radial Riveting Machines

Costly holding devices unnecessary for this and similar work.

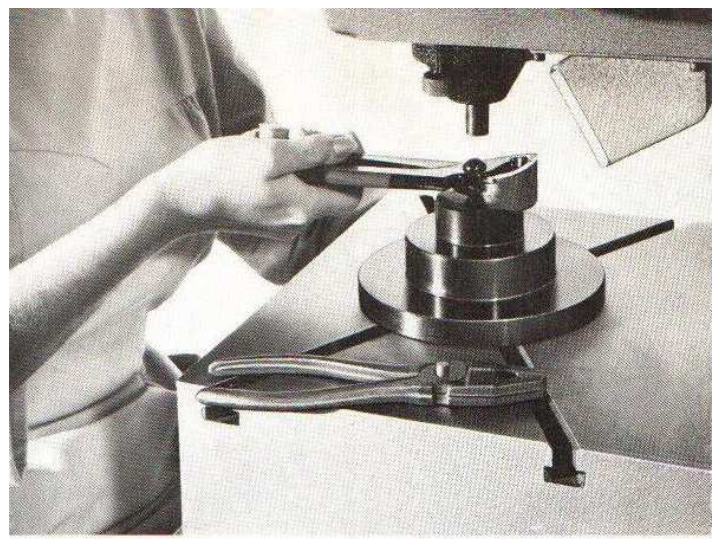

The riveting peen does not turn in rotation. It is held in place by a permanent magnet and can be slide in and out by hand.



Simple, low-cost peens for great variety of rivets.

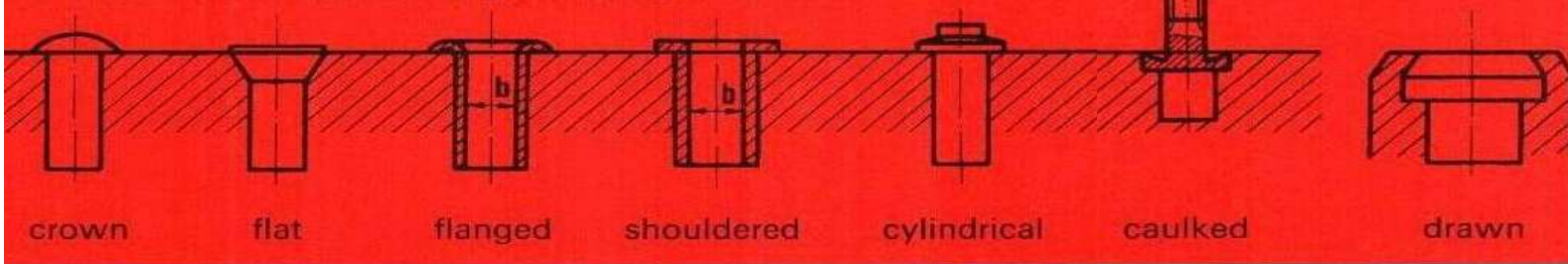

We gladly assist you in solving your riveting problems and invite you to send us your assemblies to be riveted.

Special automatic rotary feed attachment reduce riveting costs substantially.

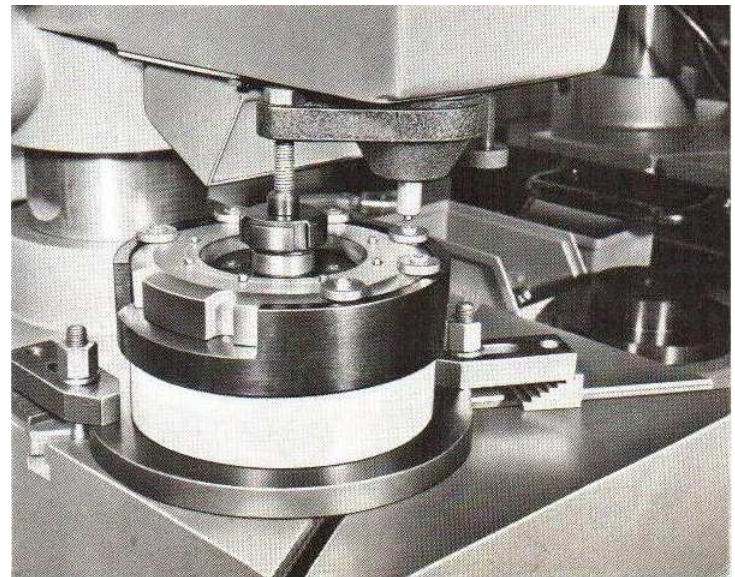

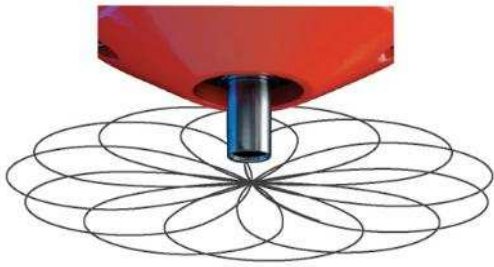

ZAGREB - MACHINES

www.zagreb.yolasite.com

Zagreb Radial Riveting Machine.



Indications regarding riveting capacity stand for steel quality St 37.

Pneumatics: By Festo Pneumatics – Germany

Electronics: PLC by Creuzet – France

Working range rivet shank in mm: 1 – 10

Air pressure in bar: 1 – 6

Working stroke in mm: 2 – 25

Riveting time in sec: 0.1 – 5.9

Working stroke adjustable with 0.01 mm

All models are equipped with stroke counter.

Panels are design to Provide: manual / semi – automatic / fully automatic riveting control.

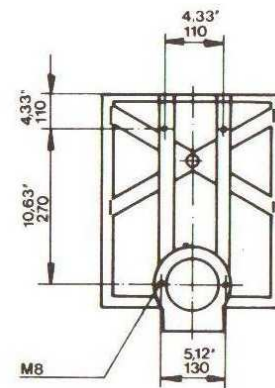
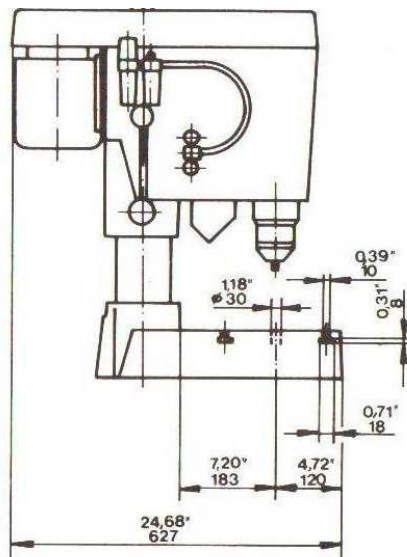
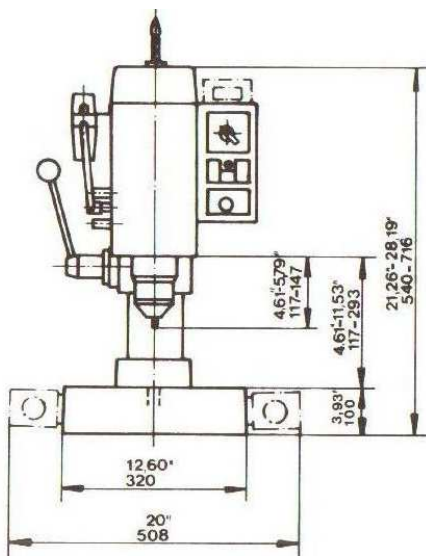



ZAGREB RADIAL'S

Few Practical
Applications
Examples

European Quality Used Worldwide Zagreb Machines

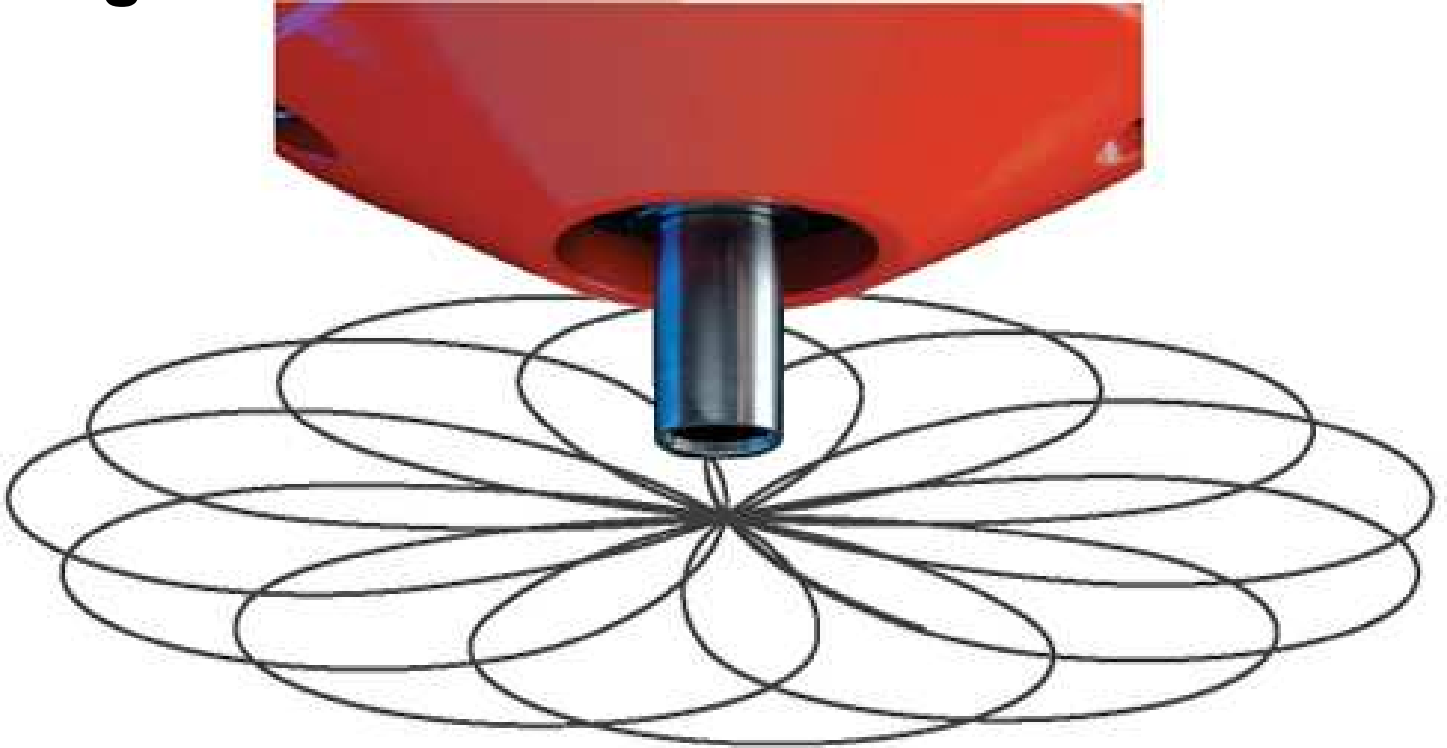

Represented by:

ZAGREB – MACHINES

Near Mahalaxmi cinema, Vadipara
Surendranagar city, zip – 363 001.
Gujarat State, INDIA.

Tel: ++91 – 94262 15629 / 98980 33362

E-mail: zagrebradial@mail.com

Web: www.zagreb.yolasite.com

Z A G R **E** B